

BIGairFANs

INDUSTRIAL AIR SUPPLY & EXHAUST FANs

WE PROVIDE
BEST QUALITY
PRODUCTS..

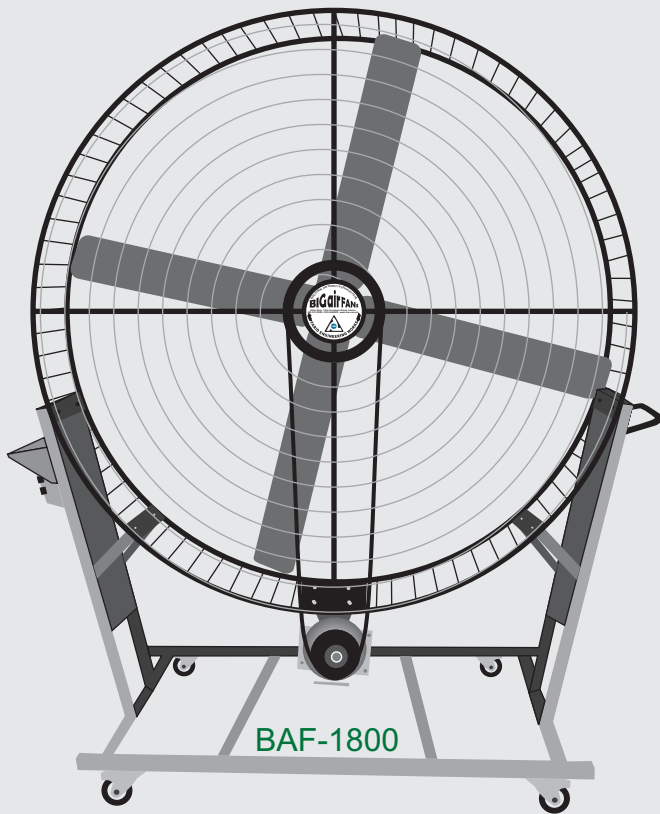

BAF-1800

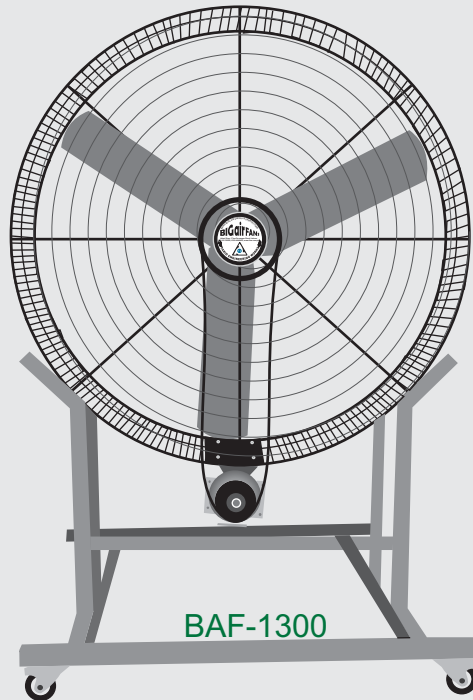

BAF-1300

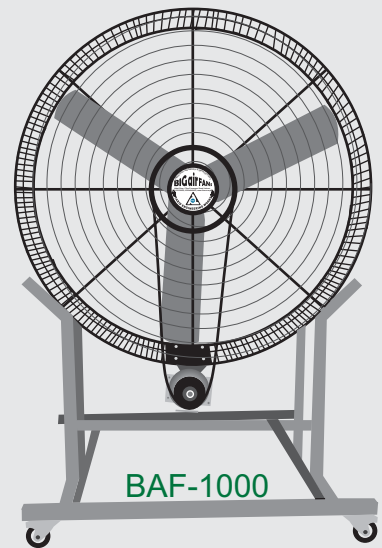

BAF-1000



FARID ENGINEERING WORKS

17-KM Ferozpur Road, Attari Stop, Lahore, Tel: +92 4235139206, Mob: 0322-4949452,
Email: info@few.com.pk, Web: www.few.com.pk

BAF-1800



Portable **BigAir Fan** 1800/1300/1000 mm

With an unrivaled balance of airflow and mobility, These models belong in every facility. We are offering a fully assembled steel frame, it's the durable and convenient choice for your dynamic airflow needs. We designed our models to use indoor/outdoor with lock able PVC wheels that can handle any terrain.

Perfect for everywhere, from narrow aisles and crowded auto shops to fitness centers and outdoor wedding venues, hotels, factories, dairy farms, and religious gatherings. Well rated for indoor and outdoor use. It is light and maneuverable enough for one to easily push around.

Key Features:-

- Easy to use and moveable.
- Creates powerful airflow that spans 100-120 feet.
- 4 aluminum blades in a powder coated cage.
- Durable rubber wheels and handles.
- Highly efficient and reliable Motor runs quietly and efficiently, keeping your people comfortable without distraction.
- Protected with a overload motor protection.

With an unrivaled balance of airflow and mobility, BAF-1300 belongs in every facility. Offering a fully assembled steel frame, it's the durable and convenient choice for your dynamic airflow needs. Best of all.

We designed BAF-1300 to use indoor/outdoor with rubber wheels that can handle any terrain. Perfect for everywhere from narrow aisles and crowded auto shops to fitness centers and outdoor wedding venues, hotels, factories, dairy farms, and religious gatherings. Well rated for indoor and outdoor use. It is light and maneuverable enough for one to easily push around.

Key Features:-

- Easy to use and moveable.
- Creates powerful airflow that spans 80-100 feet.
- 3 aluminum blades in a powder coated cage.
- Durable rubber wheels and handles.
- Highly efficient and reliable Motor runs quietly and efficiently, keeping your people comfortable without distraction.
- Protected with a overload motor protection.

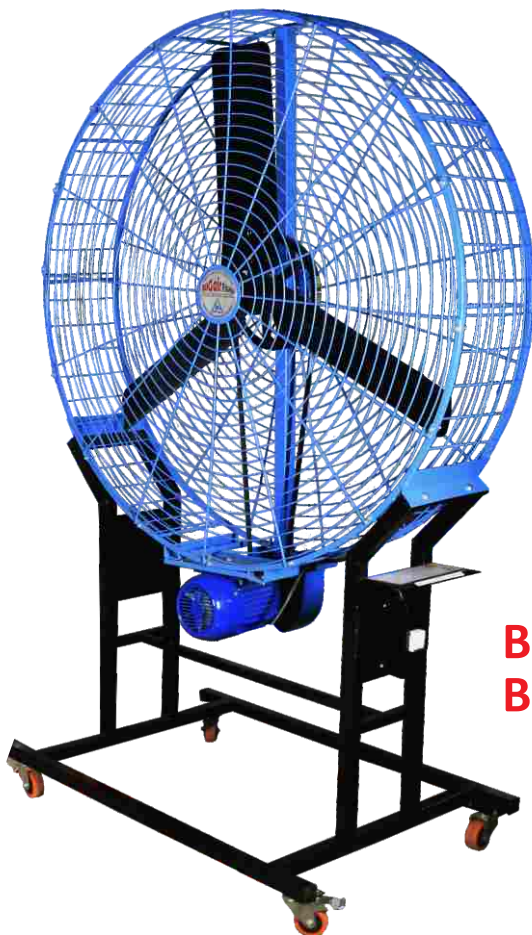

BAF-1300
BAF-1000

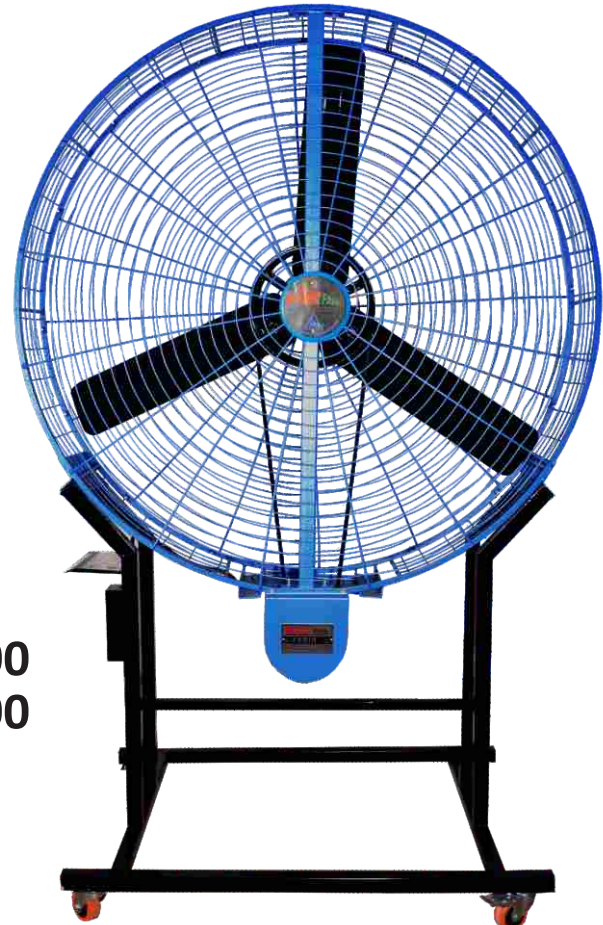

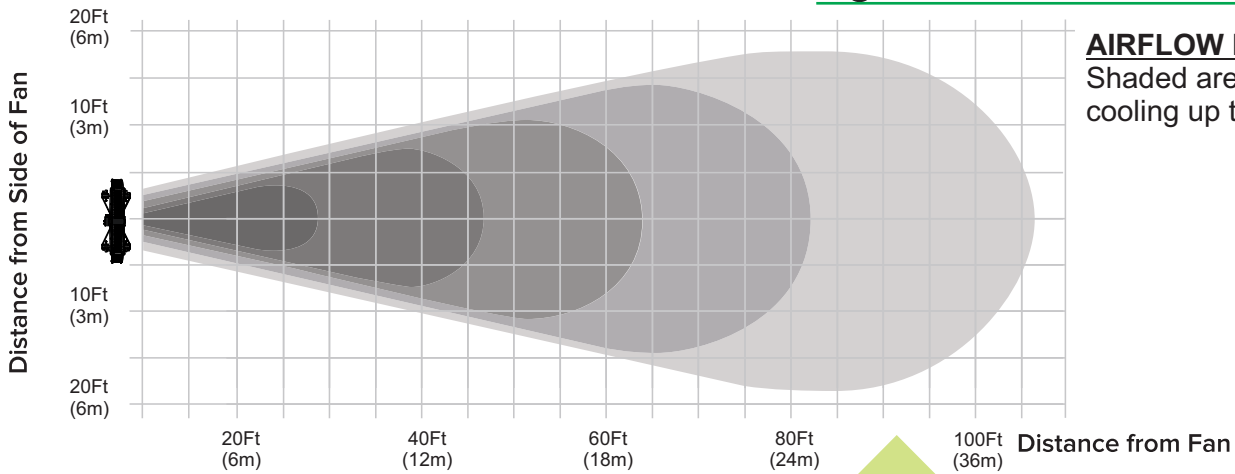
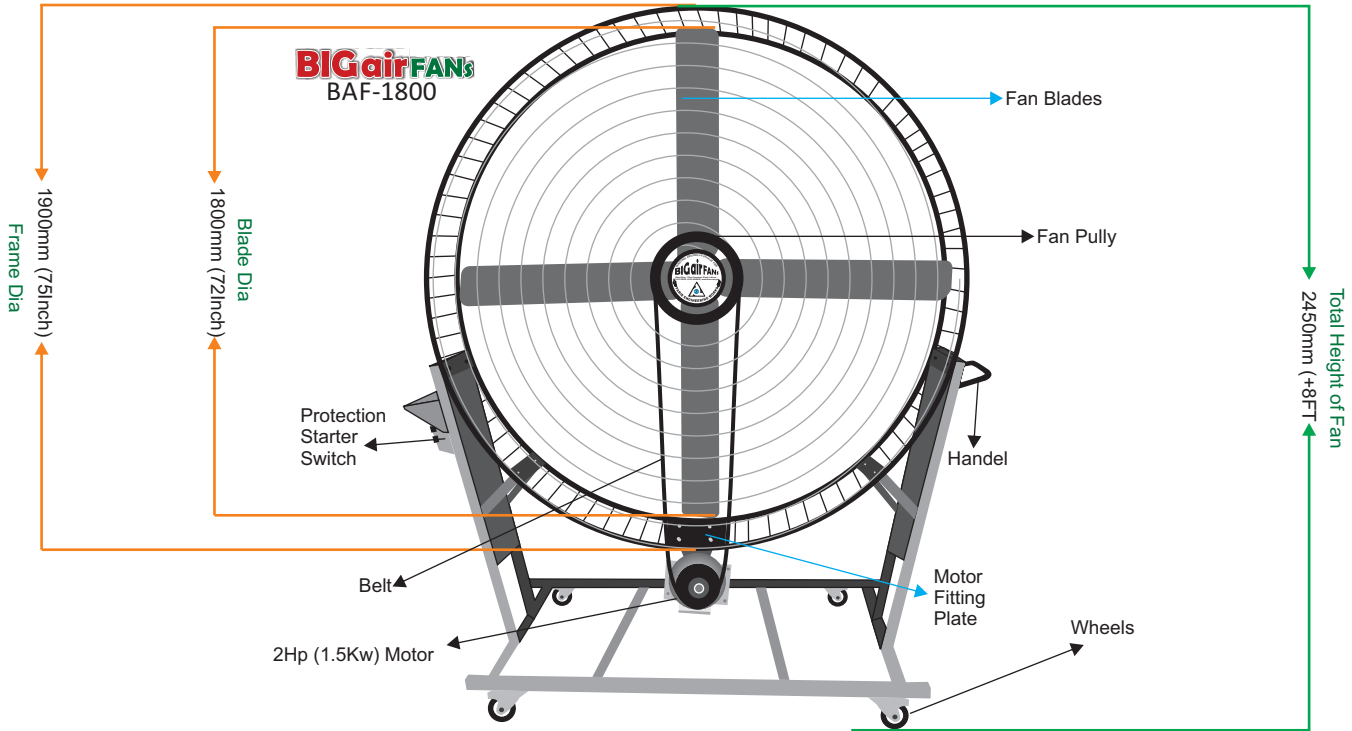

AIRFLOW DISTANCE:-
Shaded areas represent cooling up to 100ft (30M).

SPECIFICATIONS

BLADE DIA	MM/INCH	1800 / 72
OUTER DIA	MM /INCH	1900 / 76
TOTAL HEIGHT	MM/FT	2450 / 8
AIR FLOW	CFM	35000
MOTOR RATING	HP	2
SUPPLY VOLTAGE	V	400
PHASE		3
SUPPLY FREQUENCY	HZ	50
MAX CURRENT	A	3.5
ROTATIONAL SPEED	RPM	400
NOISE LEVEL	DBa	50

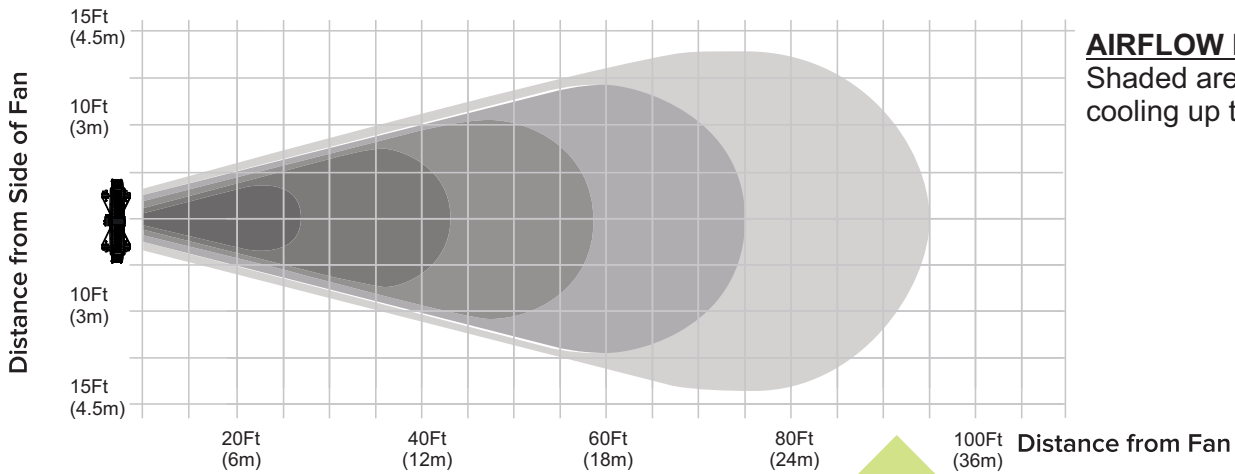
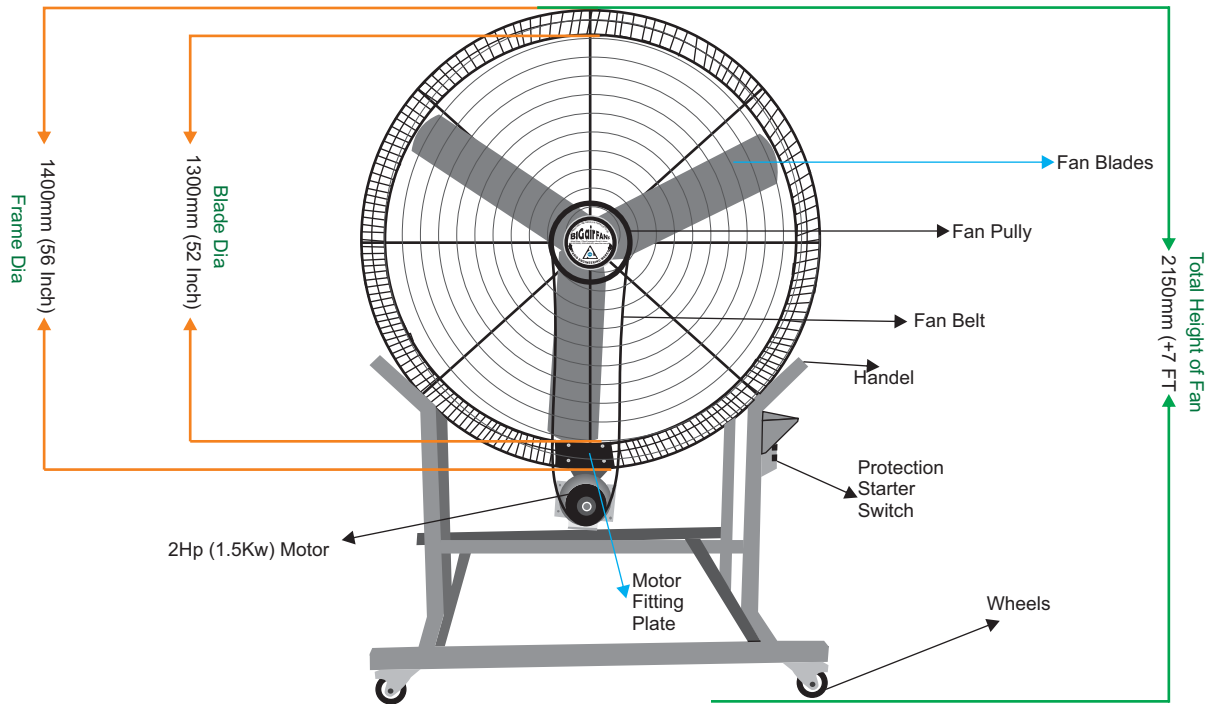

AIRFLOW DISTANCE:-
Shaded areas represent cooling up to 80ft (25M).

SPECIFICATIONS

BLADE DIA	MM/INCH	1300 / 52
OUTER DIA	MM /INCH	1400 / 56
TOTAL HEIGHT	MM/FT	2150 / 7
AIR FLOW	CFM	28000
MOTOR RATING	HP	2
SUPPLY VOLTAGE	V	400
PHASE		3
SUPPLY FREQUENCY	HZ	50
MAX CURRENT	A	3
ROTATIONAL SPEED	RPM	400
NOISE LEVEL	DBa	50

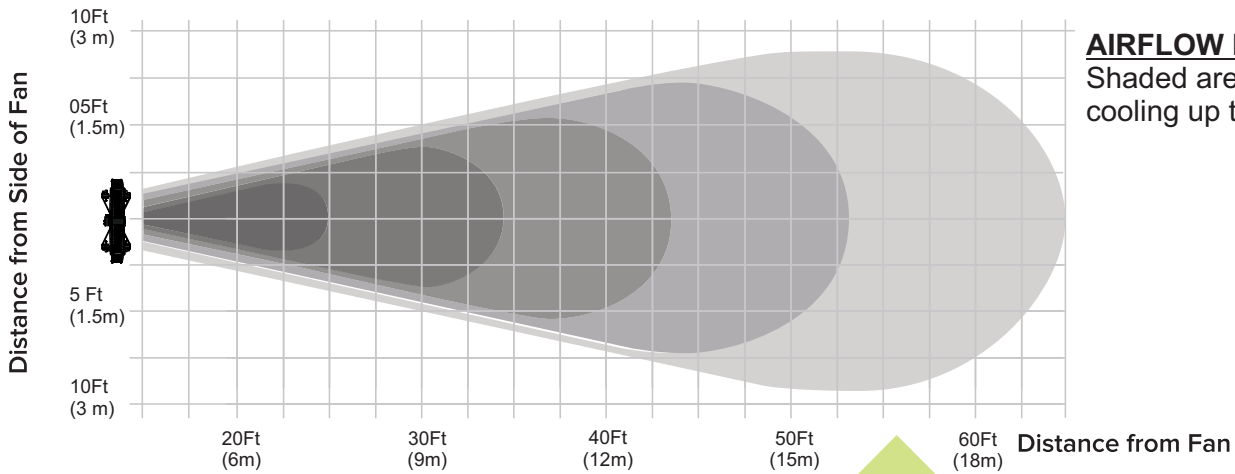
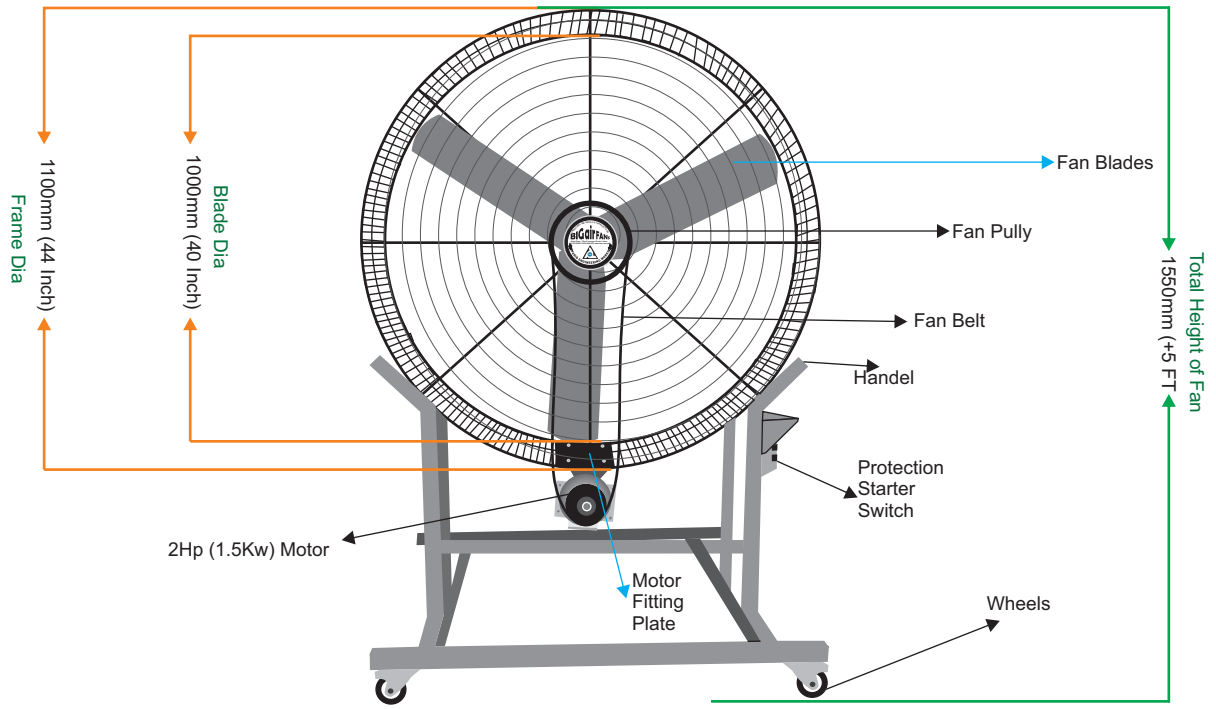

AIRFLOW DISTANCE:-
Shaded areas represent cooling up to 80ft (25M).

SPECIFICATIONS

BLADE DIA	MM/INCH	1000 / 40
OUTER DIA	MM /INCH	1100 / 44
TOTAL HEIGHT	MM/FT	1550 / 5
AIR FLOW	CFM	20000
MOTOR RATING	HP	2
SUPPLY VOLTAGE	V	400
PHASE		2.8
SUPPLY FREQUENCY	HZ	50
MAX CURRENT	A	3
ROTATIONAL SPEED	RPM	400
NOISE LEVEL	DBa	50